



Safer by design.
The JCB Teletruk Logistics Range.



Unrivalled visibility.

JCB Teletruk. The world's only telescopic counter balance forklift has been tailored to meet the demands of the logistics sector. The Teletruk's unique side mounted boom design provides unrivalled forward visibility.





Single Side Loading.

The Teletruk's unique telescopic forward reach allows you to unload trucks from one side. This means less forklift movements are required, loading in half the space, improving on-site safety and removing the need to push/pull items across the lorry bed.



Load fallen.



Load recovered and straight.

One hundred and eleven degrees of carriage rotation.

This unique benefit makes handling goods much easier and safer.

The Teletruk can also easily recover tipped or fallen loads, removing the requirement for manual handling.



Forward reach.

The Teletruk's unique telescopic forward reach allows you to reach to the load you want in the first, second or third row.

All lifts are protected by JCB's load motion control system aiding in the prevention of forward tip.



Load Motion Control System.



Van Loading.

Save time loading and unloading with the JCB Teletruk. Pick and placing from or into delivery vans reduces material and vehicle damage and eliminates the need for manual handling.



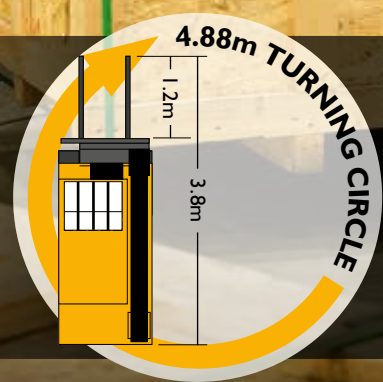
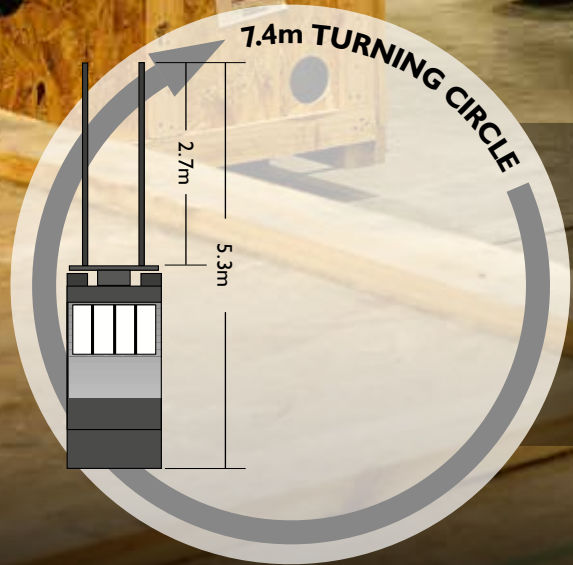
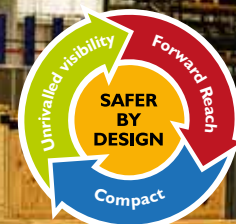

Compact and manoeuvrable.

The combination of a small footprint and a low turning radius makes the Teleruk the world's most versatile counterbalanced lift truck. With the boom retracted the JCB Teletruk has a turning radius of just 2.4m compared with a standard forklift with fork extensions at 3.7m.

Ramping Performance.

The Teletruk's compact footprint and powerful hydrostatic transmission results in excellent performance up ramps and gradients. Making it even more productive.





First choice for containers.

With a cab height of only 2.2m and full free lift as standard, the Teletruk logistics range can all easily and safely load and unload inside a container.



The JCB Teletruk offers the unique function of negative lift to reach below ground level.

Safer by a long stretch.

With it's unique telescopic reach, the JCB Teletruk eliminates the need for long fork extensions enhancing your on-site safety polices. With the same size footprint as a standard forklift, the Teletruk can also lift more weight than a standard forklift with long reach forks.



JCB TELETRUK VS STANDARD 2.5 TONNE FORKLIFT

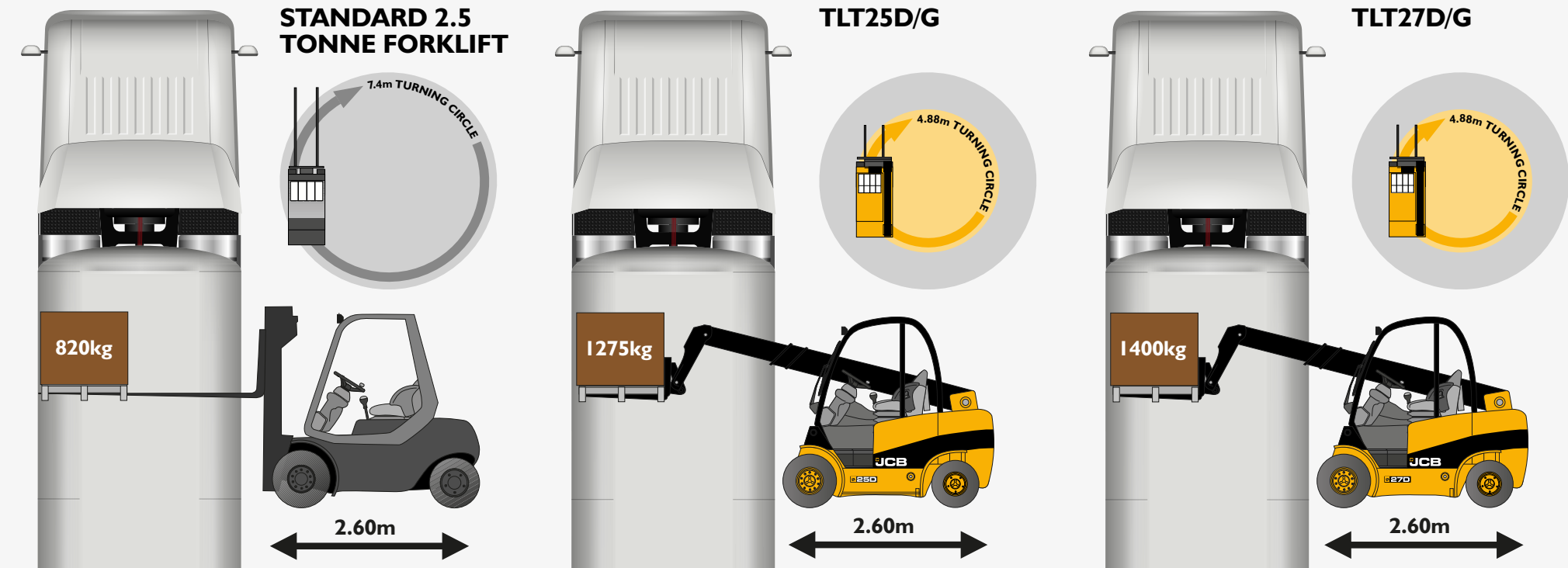

JCB TELETRUK SPECIFICATIONS		TLT25D LOGISTICS	TLT25G LOGISTICS	TLT27D LOGISTICS	TLT27G LOGISTICS
Maximum Lift Capacity	kg	2500	2500	2700	2700
Capacity @ 2m forwards reach	kg	1275	1275	1400	1400
Maximum lift height	mm	4000	4000	4000	4000
Maximum forward reach	mm	2390	2390	2390	2390
Turning Radius	mm	2440	2440	2440	2400
Aisle width 90 degree stacking	mm	3940	3940	3940	3940
Overall height (Container Ready)	mm	2190	2190	2190	2190
Overall Width	mm	1175	1175	1175	1175
Unladen Weight	kg	4220	4280	4340	4400
Carriage Rotation	Degrees	111	111	111	111
Auxiliary Flow Rates (low/High)	l/min	28/70	28/70	28/70	28/70
Negative Lift	mm	350	350	350	350

LIFT CAPACITIES – TLT25/TLT27

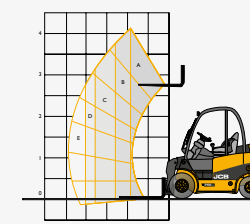

Capacity bands	TLT25D/G	TLT27D/G
A	2500 kg	2700 kg
B	2000 kg	2000 kg
C	1500 kg	1500 kg
D	1275 kg	1275 kg
E	1000 kg	1075 kg
@ 2 metres	1275 kg	1400 kg

Your nearest JCB dealer



www.jcb.com